

Benha University, Benha Faculty of Engineering	Time: 3hours, Third Year 2014/2015
Subject: Power& Elect.Machines (E1339)	Elect.Eng.Dept.

**Solve & draw as much as you can(questions in two pages)**

**Question (1)**

**[5] Points**

Draw the impedance equivalent circuit for the system shown in Fig.1 the PU values are considered the operating point values.

Rated values			Operating point PU values
G	90MVA	22KV	X=0.1PU
M	66.5MVA	10.45KV	X=0.25PU
T1	50MVA	22/220KV	X=0.2PU
T2	40MVA	220/11KV	X=0.2PU
T3	40MVA	22/110KV	X=0.3PU
T4	40MVA	110/11KV	X=0.3PU
Line 1		220KV	X=0.1PU
Line 2		110KV	X=0.54PU
Load	57MVA	lag p.f.= 0.6	Z=(0.9+J1.5)PU

Fig.1 One line diagram

**Question (2)**

**[20] Points**

The daily load on a power system varies as shown in table 1. Use the barcycle function to obtain: a- the daily load curve b-the average load c-the daily load factor

Load Mw	Interval hr	Load Mw	Interval hr	Load Mw	Interval Hr
12	12AM-2AM	12	12PM-2PM	20	8 PM -10 PM
14	2AM -6AM	24	2 PM -4 PM	16	10 PM -11 PM
16	6 AM -9 AM	16	4 PM -6 PM	16	11 PM -12 AM
18	9 AM -12 PM	20	6 PM -8 PM		

Table1

**Question (3)****[25] Points**

(a) Define: Transformer- current transformer- potential transformer?

(b) A 80KVA, 2400V:240V, 60Hz, distribution transformer has a leakage impedance of  $(0.72+j0.92) \Omega$  in the high voltage winding and  $(0.007+j0.009)\Omega$  in the low voltage winding. The exciting branch impedance viewed from the high voltage side is  $(632 \Omega // j4370 \Omega)$ . Draw the equivalent circuit and find the exciting current, the losses and efficiency if the load impedance  $(3+j4) \Omega$  is connected on the low voltage side and the input voltage is 2400V.

**Question (4)****[20] Points**

(a) A [15 hp, 220V, 2000 rpm ] separately excited DC motor drives a load requiring a torque of 50 Nm at a speed of 1200 rpm.  $R_a = 0.25\Omega, R_f = 147\Omega, K\Phi = 1.5Nm/A, V_f = 220V$ .

i-Find the armature current and the field current? ii-Find the armature voltage required?

iii-Find the efficiency? iv-Find the rated torque and rated current?

(b) Define: DC motors- Power system- Corona- Grounding- Magnetic field?

**Question (5)****[20] Points**

(a)- A three phase 460V, 60Hz, 4 poles, wye-connected induction motor has a stator impedance of  $(0.4+j0.8) \Omega$ /phase and  $(0.2+j0.8)\Omega$ /phase of the rotor winding referred to the stator side. The exciting branch impedance viewed from the stator side is  $(0 \Omega // j25 \Omega)$ . The no load loss= 80 watt and may be assumed constant. The rotor speed is 1750rpm.

i-Draw the equivalent circuit? ii-Find the  $\omega_{syn}, S, I_s, I_r, P_{gap}, P_{copper}, T_{dev}, pf, P_{inp}, P_{out}$  ?

(b) - A three phase 460V, 60Hz, 8 poles, wye-connected cylindrical rotor synchronous motor has a synchronous reactance of  $2.5 \Omega$ /phase.  $R_s$  is negligible and  $I_s=22.6A$ /phase and unity p.f.

i-Draw the equivalent circuit? ii-Find the rotor speed and torque angle?

iii-Find the  $P_{out}$  and the maximum torque?

Answer

**Question (1)**

**[51 Points]**

Draw the impedance equivalent circuit for the system shown in Fig.1 the PU values are considered the operating point values.

Rated values			Operating point PU values
G	90MVA	22KV	X=0.2PU
M	66.5MVA	10.45KV	X=0.25PU
T1	50MVA	22/220KV	X=0.2PU
T2	40MVA	220/11KV	X=0.15PU
T3	40MVA	22/110KV	X=0.16PU
T4	40MVA	110/11KV	X=0.2PU
Line 1		220KV	X=0.1PU
Line 2		110KV	X=0.54PU
Load	57MVA	lag p.f.= 0.6	Z=(0.95+J1.3)PU

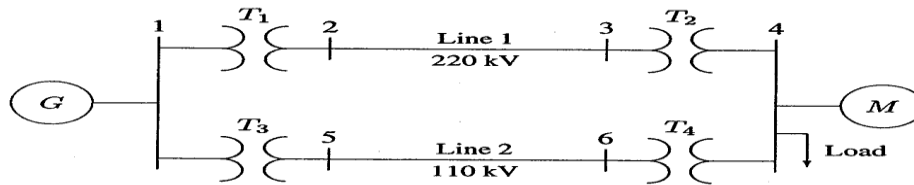
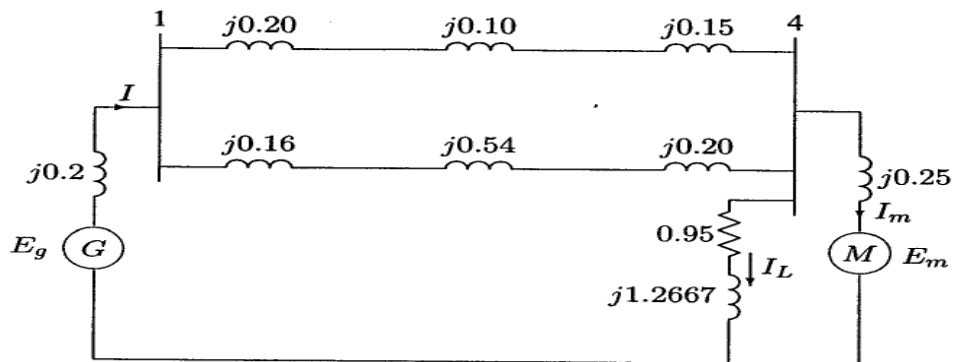

Fig.1 One line diagram



**Question (2)**

**[201 Points]**

The daily load on a power system varies as shown in table 1. Use the barcycle function to obtain:

- a- the daily load curve
- b-the average load
- c-the daily load factor

Load Mw	Interval hr	Load Mw*hr
12	12AM-2AM=2	24
14	2AM -6AM=4	28
16	6 AM -9 =3	48
18	9 AM -12 =3	36
12	12PM-2PM=2	24
24	2 PM -4 PM=2	48
16	4 PM -6 PM=2	32
20	6 PM -8 PM=2	40
20	8 PM -10 =2	40
16	10 PM -11 =1	16
16	11 PM -12 =1	16
Max=24MW	=24hr	Total=352MWhr

Table1

$$P_{avg} = 352/24 = 14.7 \text{ Mw, Peak load} = 24 \text{ Mw}$$

$$LF = 100 * P_{avg} / \text{Peak load} = 14.7 * 100 / 24 = 61.1\%$$

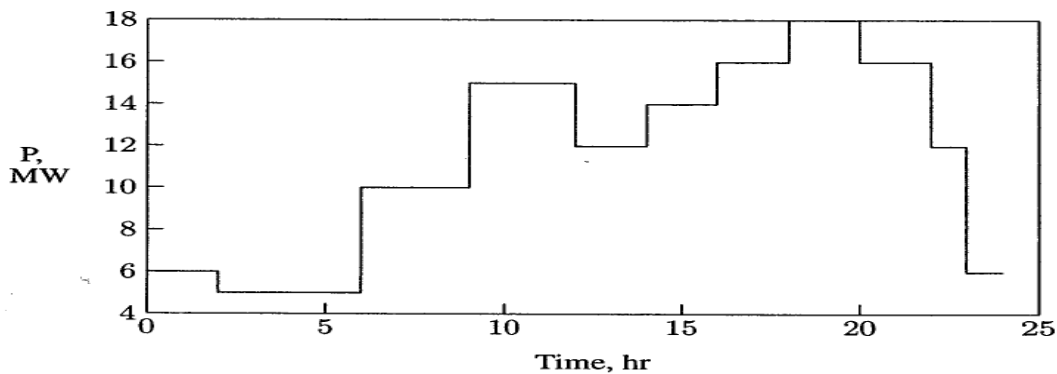

**FIGURE 1.2**  
Daily load cycle for Example 1.1.

**Question (3)**

**[25] Points**

(a) Define: Transformer- current transformer- potential transformer?

**Transformers** The principle of transformer action is based on the electromagnetic induction between two magnetically coupled coils a changing current in one coil will induce an electromotive force in the other coil. Such electromagnetically induced emfs are called transformer voltages. Transformers are very versatile.

They are used to:

- 1-raise or lower voltage in AC distribution and transmission systems;
- 2-provide reduced-voltage starting of AC motors; to isolate one electric circuit from another;
- 3-superimpose an alternating voltage on a DC circuit;
- 4-provide low voltage for solid-state control, for battery charging, door bells, etc.

Types depend on Construction

- 1-Core type coils wound on different legs
- 2-Shell type both coils wound on the same leg

1-Instrument transformers are used to transform high currents and high voltages to low values for instrumentation and control.

2-Instrument potential-transformers PT are used in voltage measurements. PT is a very accurate two-winding transformer, whose primary is connected across the voltage it is to measure, and whose secondary is connected to a voltmeter or high-impedance relay.

3-Instrument current-transformers CT are used in current measurements. The primary of the CT is connected in **series** with the load circuit, and the secondary is connected to the instruments and/or relays,

4-Both types also serve to insulate the low-voltage instruments from the high-voltage system.

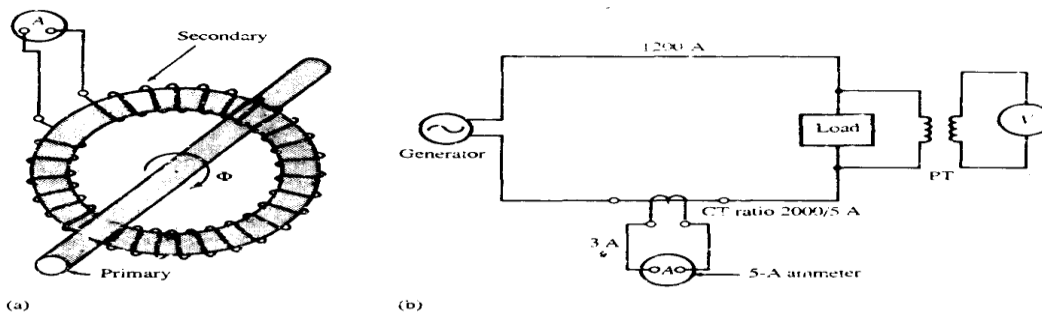

**Figure 3-18 Current transformer; (a) window type; (b) circuit connections.**

(b) A 80KVA, 2400V:240V, 60Hz, distribution transformer has a leakage impedance of  $(0.72+j0.92) \Omega$  in the high voltage winding and  $(0.007+j0.009)\Omega$  in the low voltage winding. The exciting branch impedance viewed from the high voltage side is  $(632 \Omega \parallel j4370 \Omega)$ . Draw the equivalent circuit and find the exciting current, the losses and efficiency if the load impedance  $(3+j4) \Omega$  is connected on the low voltage side and the input voltage is 2400V.

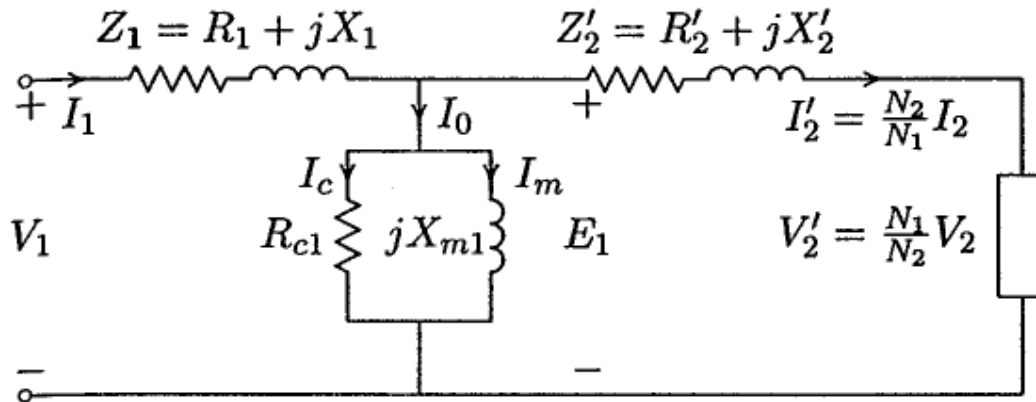

**FIGURE 3.10**

Exact equivalent circuit referred to the primary side.

$$Z'_2 + Z'_L = a^2 (Z_2 + Z_L) = 10^2 (3.007 + j4.009) = 300.7 + j400.9 = 501.14 \angle 52.13^\circ \Omega,$$

$$Z_m = R_{fe} + jX_m = 632 + j4370 = 4415.5 \angle 81.8^\circ \Omega, \quad (932.7 + j4770.9) = 4861.22 \angle 78.94^\circ \Omega,$$

$$(Z'_2 + Z'_L) \parallel Z_m = 2212783.67 \angle 133.93^\circ / (4861.22 \angle 78.94^\circ) = 455.2 \angle 55^\circ \Omega$$

$$Z_{in} = 0.72 + j0.92 + 261.1 + j372.9 = 261.82 + j373.82 = 456.4 \angle 55^\circ \Omega$$

$$I_p = (2400 \angle 0^\circ / 456.4 \angle 55^\circ) = 5.3 \angle -55^\circ \text{ A}$$

$$I_0 = 5.3 \angle -55^\circ (501.14 \angle 52.13^\circ / 4861.22 \angle 78.94^\circ) = 0.55 \angle -81.8^\circ \text{ A}$$

$$I'_L = 5.3 \angle -55^\circ (4415.5 \angle 81.8^\circ / 4861.22 \angle 78.94^\circ) = 4.8 \angle -52.14^\circ \text{ A}$$

$$\text{Core losses} = I_M^2 R_{fe} = 0.55^2 * 632 * \cos(81.8^\circ) = 27.3 \text{ W}$$

$$\text{Copper losses} = I_L^2 R_{eq} = 4.8^2 * 1.42 = 32.72 \text{ W}$$

$$\text{Output power} = I'_L{}^2 R'_L = 4.8^2 * 30 = 691.2 \text{ W}$$

$$\eta = p_{out} / p_{in} = p_{out} / (p_{out} + \text{losses}) = 691.2 / 751.22 = 0.92$$

+

**Question (4)**

**[20] Points**

(a) A [15 hp, 220V, 2000 rpm ] separately excited DC motor drives a load requiring a torque of 50 Nm at a speed of 1200 rpm.  $R_a = 0.25\Omega, R_f = 147\Omega, K\Phi = 1.5Nm/A, V_f = 220V$ .

- i-Find the armature current and the field current? ii-Find the armature voltage required?
- iii-Find the efficiency? iv-Find the rated torque and rated current?

$$T_{mech} = K_a \Phi_d i_a \quad e_a = K_a \Phi_d \omega_m$$

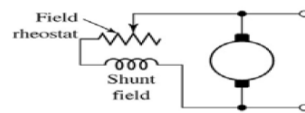

In a motor the relation between the emf  $E_a$  generated in the armature and the armature terminal voltage  $V_a$  is

$$V_a = E_a + I_a R_a \tag{7.11}$$

$$I_a = \frac{V_a - E_a}{R_a} \tag{7.12}$$

Torque and power:

The electromagnetic torque  $T_{mech}$

$$T_{mech} = K_a \Phi_d I_a$$

The generated voltage  $E_a$

$$E_a = K_a \Phi_d \omega_m$$

$$K_a = \frac{\text{poles} C_a}{2\pi m}$$

$E_a I_a$  : electromagnetic power

$$T_{mech} = \frac{E_a I_a}{\omega_m} = K_a \Phi_d I_a$$

$$I_f = 220/147 = 1.5A, I_a = 50/1.5 = 33.3A, E_a = 1200 * 2\pi * 1.5 / 60 = 188.5V$$

$$V_a = V_a = E_a + I_a R_a = 188.5 + 33.3 * 0.25 = 196.82V$$

$$P_{\text{inp}} = 196.82 \times 33.3 + 220 \times 1.5 = 6884.125 \text{ W}, P_{\text{out}} = 1200 \times 2\pi \times 50 / 60 = 6283.2 \text{ W},$$

$$\eta = 6283.2 / 6884.125 = 91.27\%, T_{\text{rat}} = P_{\text{rat}} / \omega_{\text{rat}} = 15 \times 746 \times 60 / (2000 \times 2\pi) = 53.43 \text{ Nm}$$

$$I_{\text{rat}} = P_{\text{rat}} / V_{\text{rat}} = 15 \times 746 / 220 = 51 \text{ A} \text{ or } I_{\text{rat}} = T_{\text{rat}} / 1.5 = 35.62 \text{ A}$$

(b) Define: DC motors- Power system- Corona- Grounding- Magnetic field?

Dc machines are characterized by their versatility.

- ⌚ By means of various combinations of shunt-, series-, and separately-excited field windings they can be designed to display a wide variety of volt-ampere or speed-torque characteristics for both dynamic and steady-state operation.

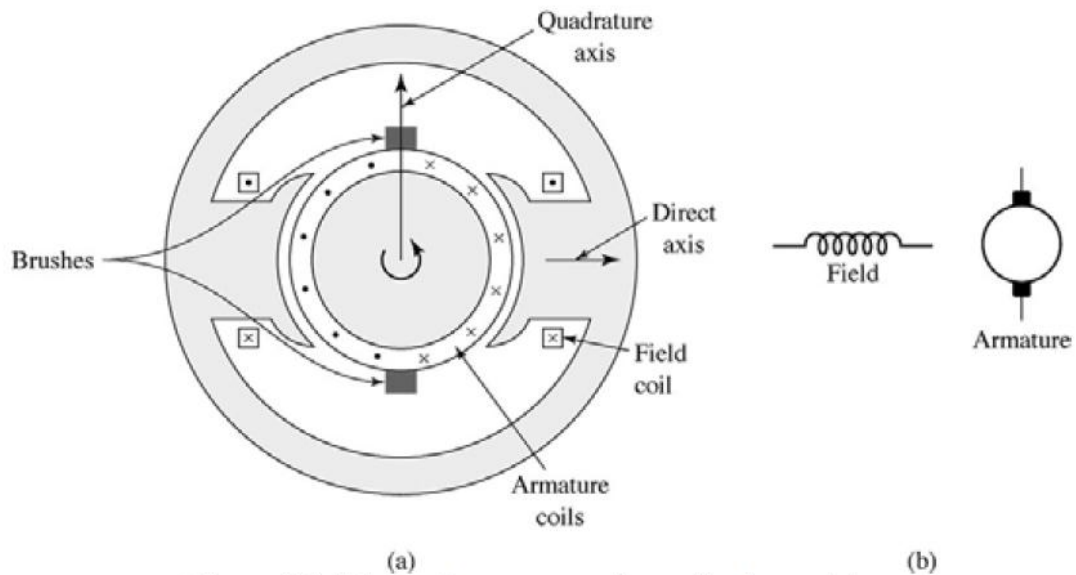

Figure 7.1 Schematic representations of a dc machine.

$$T_{\text{mech}} = K_a \Phi_d i_a$$

$K_a$ : a constant determined by the design of the winding, the winding constant

$i_a$  = current in external armature circuit

$C_a$  = total number of conductors in armature winding,

$m$  = number of parallel paths through winding

The rectified voltage  $e_a$  between brushes, known also as the speed voltage, is

$$e_a = K_a \Phi_d \omega_m$$

Note that the electric power equals the mechanical power.

$$e_a i_a = T_{\text{mech}} \omega_m$$



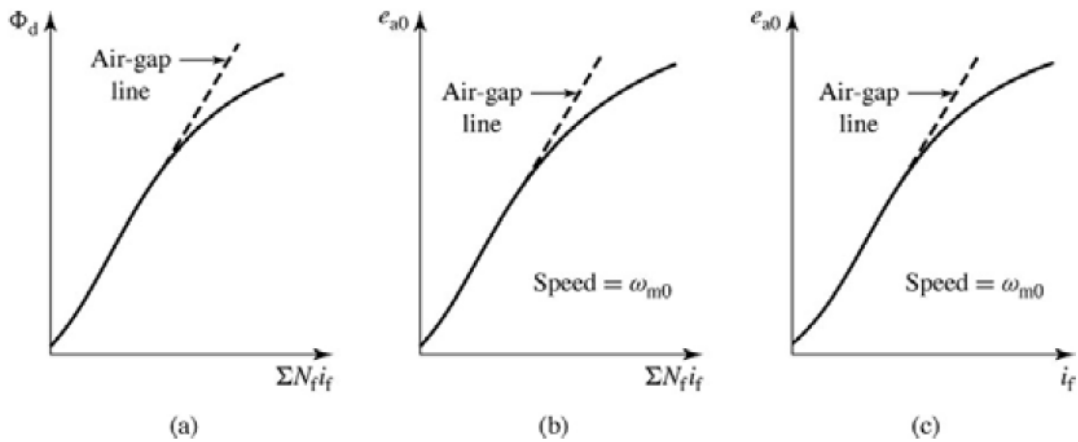

Figure 7.3 Typical form of magnetization curves of a dc machine.

Various methods of excitation of the field windings are shown in Fig. 7.4.

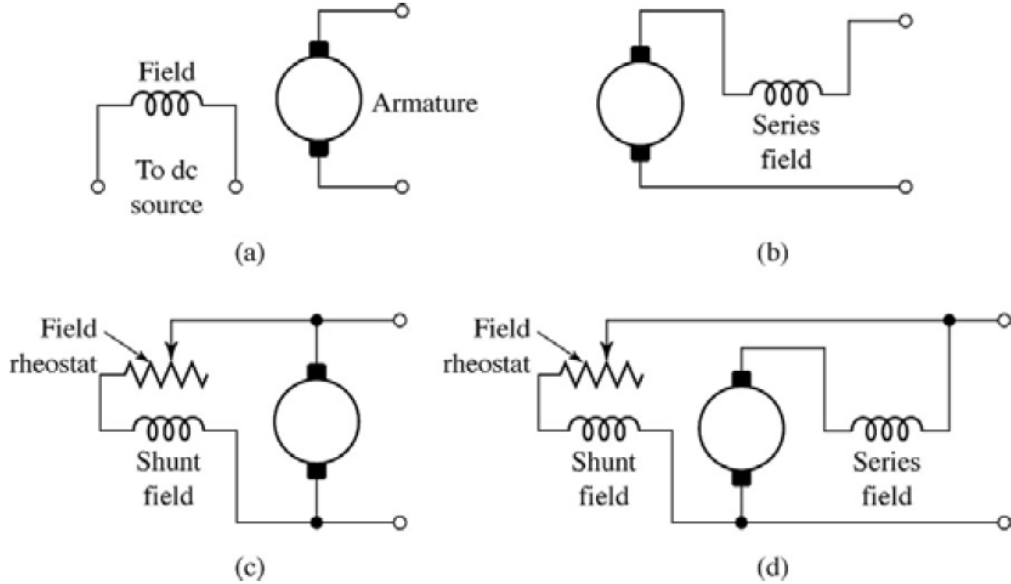

Figure 7.4 Field-circuit connections of dc machines:  
 (a) separate excitation, (b) series, (c) shunt, (d) compound.

**Power system** is a system consists of 1-generation 2-transformation up 3-transmission 4- transformation down 5-distribution 6-loads 7-protection system.

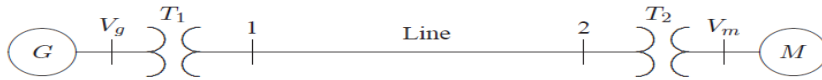

FIGURE 30  
One-line diagram for Problem 3.15

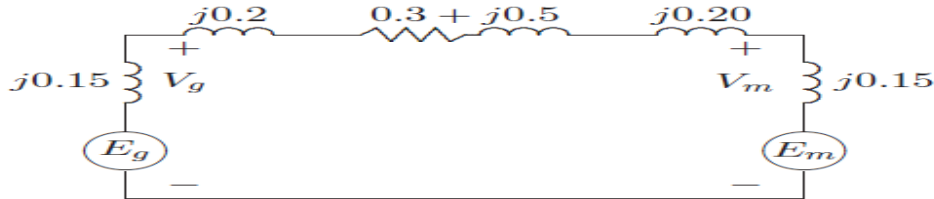

FIGURE 31  
Per unit impedance diagram for Problem 3.15.

#### 4.19 CORONA

When the surface potential gradient of a conductor exceeds the dielectric strength of the surrounding air, ionization occurs in the area close to the conductor surface. This partial ionization is known as *corona*. The dielectric strength of air during fair weather and at NTP (25°C and 76 cm of Hg) is about 30 kV/cm.

Corona produces power loss, audible hissing sound in the vicinity of the line, ozone and radio and television interference. The audible noise is an environmental concern and occurs in foul weather. Radio interference occurs in the AM band. Rain and snow may produce moderate TVI in a low signal area. Corona is a function of conductor diameter, line configuration, type of conductor, and condition of its surface. Atmospheric conditions such as air density, humidity, and wind influence the generation of corona. Corona losses in rain or snow are many times the losses during fair weather. On a conductor surface, an irregularity such as a con-

**Ground** is defined as a conducting connection by which a circuit or equipment is connected to the earth. A "ground" consists of a grounding conductor, a grounding electrode, a grounding connector which attaches the grounding conductor to the ground electrode, and the soil in contact with the ground electrode. It used to protect persons or animals against the danger of electric shock and maintain the proper function of the electrical system.

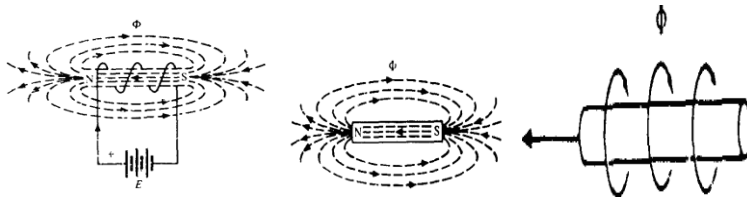

FIGURE 1-1 Direction of magnetic flux: (a) around a current-carrying conductor; (b) in a coil; (c) about a magnet.

**A magnetic field** is a condition resulting from electric charges in motion. The magnetic field of a permanent magnet is attributed to the uncompensated spinning of electrons about their own

axis within the atomic structure of the material and to the parallel alignment of these electrons with similar uncompensated

**Question (5)**

**[20] Points**

(a)- A three phase 460V, 60Hz, 4 poles, wye-connected induction motor has a stator impedance of  $(0.4+j0.8) \Omega$ /phase and  $(0.2+j0.8)\Omega$ /phase of the rotor winding referred to the stator side. The exciting branch impedance viewed from the stator side is  $(0 \Omega // j25 \Omega)$ . The no load loss= 80 watt and may be assumed constant. The rotor speed is 1750rpm.

i-Draw the equivalent circuit? ii-Find the  $\omega_{syn}$ , S,  $I_s$ ,  $I_r$ ,  $P_{gap}$ ,  $P_{copper}$ ,  $T_{dev}$ , pf,  $P_{inp}$ ,  $P_{out}$  ?

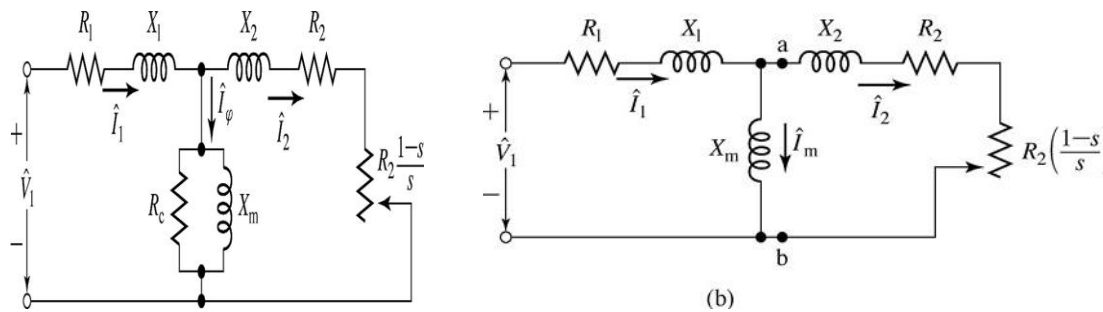

Figure 6.9 Single-phase equivalent circuit for a three-phase induction motor.

Equivalent circuits with the core-loss resistance  $R_c$  neglected

$$P_{mech} = \omega_m T_{mech} = (1-s)\omega_s T_{mech}$$

$$T_{mech} = \frac{P_{mech}}{\omega_m} = \frac{P_{gap}}{\omega_s} = \frac{n_{ph} I_2^2 (R_2/s)}{\omega_s}$$

$$\omega_s = \frac{4\pi f_e}{\text{poles}} = \left( \frac{2}{\text{poles}} \right) \omega_e$$

$$P_{shaft} = P_{mech} - P_{rot}$$

$$T_{shaft} = \frac{P_{shaft}}{\omega_m} = T_{mech} - T_{rot}$$

The slip is often expressed in percent.  
 $n$  : rotor speed in rpm

$$n = (1-s)n_s$$

$\omega_m$  : mechanical angular velocity

$$\omega_m = (1-s)\omega_s$$

$$P_{gap} = n_{ph} I_2^2 \left( \frac{R_2}{s} \right)$$

$$P_{rotor} = n_{ph} I_2^2 R_2$$

$$P_{rotor} = n_{ph} I_2^2 R_2$$

$$P_{mech} = P_{gap} - P_{rotor} = n_{ph} I_2^2 \left( \frac{R_2}{s} \right) - n_{ph} I_2^2 R_2$$

$$P_{mech} = n_{ph} I_2^2 R_2 \left( \frac{1-s}{s} \right)$$

$$P_{mech} = (1-s)P_{gap}$$

$$P_{rotor} = sP_{gap}$$

$$S = (1800 - 1750) / 1800 = 0.03, n_s = 120 * 60 / 4 = 1800 \text{ rpm}, \omega_s = 1800 * \pi / 30 = 188.5 \text{ rad/s}$$

$$n_r = (1 - S)n_s = 1750 \text{ rpm}, \omega_r = 947.5 * \pi / 30 = 182.845 \text{ rad/s}$$

$$\frac{R'_2}{S} = \frac{0.2}{0.03} = 6.7 \Omega, Z'_2 = 6.7 + j0.8 = 6.73 \angle 7^\circ \Omega,$$

$$j25 // Z'_2 = 0.24 \angle 21.6^\circ = 0.223 + j0.09 \Omega$$

$$(j25 // Z'_2) + Z_1 = 0.623 + j0.89 = 1.1 \angle 55^\circ \Omega, 460 / \sqrt{3} = 265.6 \angle 0^\circ \text{ V}$$

$$I_s = (265.6 \angle 0^\circ / 1.1 \angle 55^\circ) = 241.44 \angle -55^\circ \text{ A}$$

$$I_r = 241.44 \angle -55^\circ * 25 \angle 90^\circ / 26.7 \angle 75.4^\circ = 226.1 \angle -40.4^\circ \text{ A}$$

$$\text{Copper losses} = I_L^2 R_{eq} = W$$

$$\text{Output power} = P_{gap} - \text{losses} =$$

$$\eta = P_{out} / P_{in} = P_{out} / (P_{out} + \text{losses}) =$$

$$P_{mech} = \quad = W, T_{mech} = \quad = \text{Nm}$$

$$P_{shaft} = W, T_{shaft} = \text{Nm}$$

**(b)** - A three phase 460V, 60Hz, 8 poles, wye-connected cylindrical rotor synchronous motor has a synchronous reactance of 2.5  $\Omega$ /phase.  $R_s$  is negligible and  $I_s = 22.6 \text{ A}$ /phase and unity p.f.

i-Draw the equivalent circuit? ii-Find the rotor speed and torque angle?

iii-Find the  $P_{out}$  and the maximum torque?

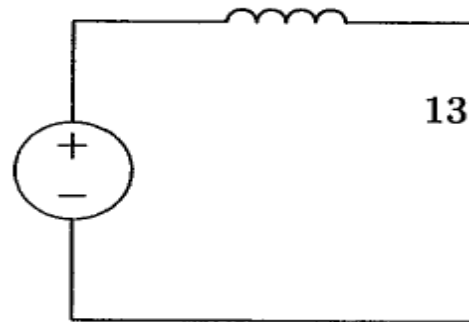
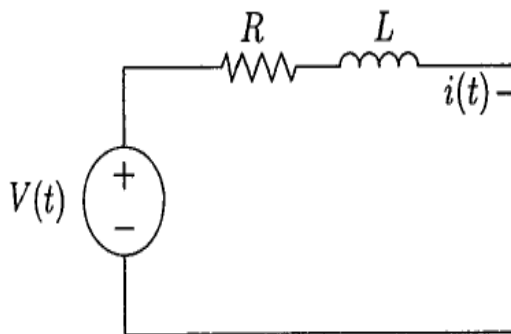

$$n_r = n_s = 120 * 60 / 8 = 900 \text{ rpm}, \omega_r = \omega_s = 900 * \pi / 30 = 94.25 \text{ rad/s}$$

$$V_f = V_t - jI_a X_s = 460/\sqrt{3} = 265.6 \angle 0 - j22.6 * 2.5 = 265.6 - j56.5 = 271.54 \angle -22.6^\circ$$

$$\text{Torque angle} = \delta = -22.6^\circ, P_{\text{out}} = \frac{3V_f * V_t * \sin \delta}{X_s} = \frac{3 * 271.54 * 265.6 \sin 22.6}{2.5} = 5769.6W$$

$$T_{\text{max}} = \frac{3V_f * V_t}{\omega_s X_s} = \frac{3 * 271.54 * 265.6}{94.25 * 2.5} = 918.25Nm$$